



Swaraj 841XM with Leveller



Swaraj 841XM with Rotavator



Swaraj 841XM with Seed Drill

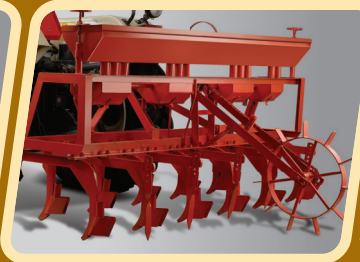

Swaraj 841XM with Potato Planter



Swaraj 841XM with Trolley



**Specifications**

**Engine**

Model : MDI 2385S 3A  
 HP grade : 29.82 kW (40 HP) range  
 Type : 4 stroke, direct injection, diesel engine  
 Number of Cylinders : 4  
 Boar and stroke : 88.90 x 110 mm  
 Displacement : 2730 cm<sup>3</sup>  
 Rated Engine Speed : 1900 r/min  
 Air Cleaner : 3-stage oil bath type  
 Cooling System : Water cooled with no loss tank

**Transmission**

Clutch : Single diaphragm type 280 mm diameter, Dual clutch 280 mm diameter (optional)  
 Number of Gears : 8 forward, 2 reverse speed, gear speed (km/h) with 152.40 X 406.40 mm (6.00 x 16) front and 314.96 X 711.20 mm (12.40 x 28) rear type  
 Forward : 2.30 to 29.30  
 Reverse : 2.80 and 10.90  
 P.T.O. : Live P.T.O. 540 r/min with similar to 1800 r/min engine  
 Breaks : Oil immersed brakes

**Hydraulic and Implement Linkage**

Hydraulics : A) Live Hydraulics  
 : B) Sensilift hydraulics for better performance in pulverized and sandy land  
 A) Position control : To hold lower links at any desired height  
 B) Automatic Draft Control : To maintain uniform depth  
 C) Mix Control : For simultaneous use of position and draft controls for optimum field output  
 Lifting capability : 1200 kg at lower link ends  
 Linkage : 3-point suitable for Category-I & Category-II type implement pins

**Steering**

Steering : Heavy duty single drop arm steering for high efficiency and comfortable drive

**Weight and Dimensions**

Full length : 3240 mm  
 Full width : 1770 mm  
 Full height : 2220 mm  
 Wheel base : 1950 mm  
 Min. ground clearance : 293 mm  
 Weight of tractor : 1820 kg  
 Wheel Track : Front 1335 - 1565 mm Rear 1350 - 1890 mm (With 314.96 X 711.20 mm (12.40 x 28) tyre size)

**Tyres**

Standard : Front 152.40 X 406.40 mm (6.00 x 16), Rear 314.96 X 711.20 mm (12.40 x 28)  
 {Optional Front 152.40 X 406.40 mm (6.00 x 16), Rear 345.44 X 711.20 mm (13.60 x 28)}

**Electricals and Instruments**

Electricals : 12 volt 88 A battery, starter motor and alternator  
 Instruments : r/min and hour meter, direction indicators, ammeter, fuel gauge, water temperature gauge and oil pressure gauge

**Features of New and advance hydraulics**

- > Live Hydraulics
- > Advanced and sensilift hydraulics for better performance in pulverized and sandy land
- > Controlled loading speed for better hydraulic operation in pulverized and sandy land
- > Square lift rod provided to get more transport height
- > Acquired slide adjustable stabilizer bar for implement swing control
- > Transport lock provided for heavy loads/machines
- > 1200 kg lifting capacity
- > Isolator valve like tipping trolley for external use

\*For improvements in the products, specifications could be changed zout prior notice. The model shown here is only for representative purpose. Actual product may defer.

Warranty : 2 years or 2000 hours, whichever is earlier



**SWARAJ DIVISION,**  
 Phase IV, Industrial Area, S. A. S. Nagar, Mohali,  
 Punjab-160 055. Phone: 0172 2271620 to 27; 0172 227820 to 23  
 Website: www.swarajtractors.com

Authorised dealer:



PRESENTING **SWARAJ 841 XM**  
**ALL ROUNDER IN**  
**FARMING AND HAULAGE**



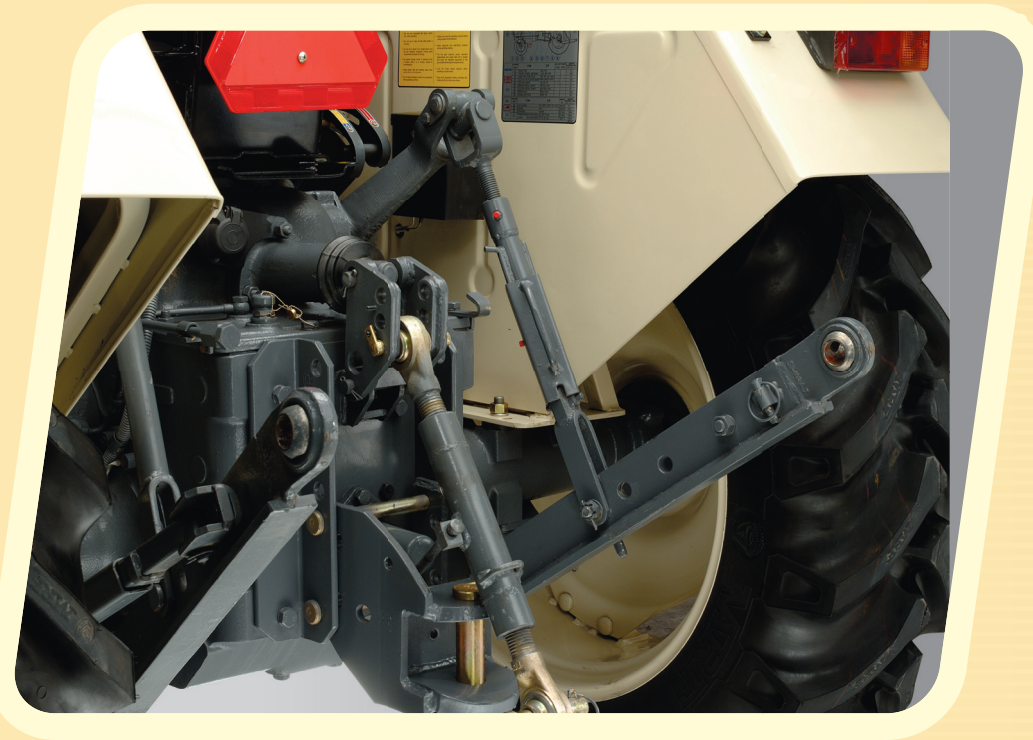

# Sensilift hydraulics

Sensilift hydraulics is specifically made by Swaraj to work easily in pulverized and sandy lands. Sensilift hydraulics is specifically made with better control valve which helps in maintaining uniform depth in sowing and pushes the sandy mud to make proper level. Sensilift hydraulics is available in 1200 kg capacity which helps in lifting the trolley with heavy load and is useful to work with heavy equipments like Disc Harrow and Seed Drill.

### Special features of Sensilift hydraulics :

- † **3 point linkage compatibility:** Pulls maximum mud with minimum resistance in levelling work
- † **1200 kg Life Capacity:** Operates heavy equipments easily
- † **Live Hydraulics:** Hydraulics work even after releasing the clutch
- † **Transport Height:** Easily does field work on sandy slopes and crosses the ram.



**Better hydraulic lever**  
Easy operation



**Hydraulic pump with more flow**  
Hydraulic works quickly and in a better way



**Better control valve**  
Helps in maintaining uniform depth in sowing and pushes the sandy mud to make proper level.

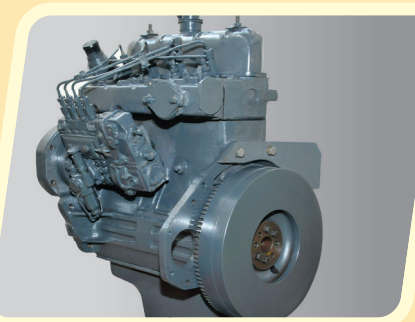

**Strong efficient engine**  
for longer life and more saving



**Compact design**  
Light weight and compact design protects it from sandy mud from slipping

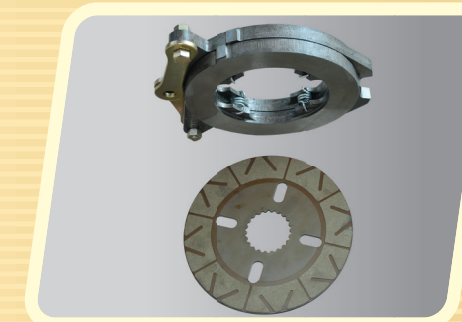

**Oil immersed brakes**  
for powerful braking

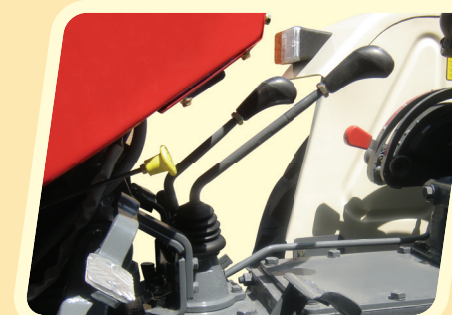

**8F+2R, Sliding and Constant mesh with gears**  
Easy gear shifting and comfortable drive

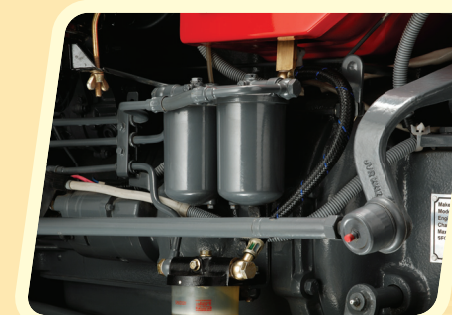

**Single drop arm**  
Smaller turning radius

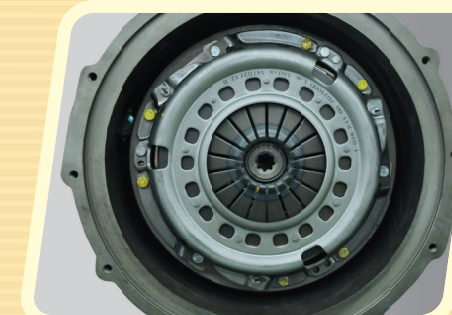

**Diaphragm clutch**  
For longer life and more comfort



**Mobile charging point**  
Charge your mobile while working on the field



**345.44 X 711.2 mm (13.6 x 28) rear tyre**  
For strong hold in tillage and other work

## New Fuel Efficient 841XM

Swaraj tractor, the first choice of the farmers. A powerful engine with 1900 rated r/min makes every job easy and increases the life of the tractor. Unparalleled features and attractive design make Swaraj Tractor, an invaluable asset for its farmer.